

STANDARD EQUIPMENT

ISO Standard cabin
All-weather steel cab with 360° visibility
Safety glass windows
Rise-up type windshield wiper
Sliding fold-in front window
Sliding side window(LH)
Lockable door
Hot & cool box
Storage compartment & Ashtray
Radio & USB player
Cabin roof-steel cover
12 volt power outlet (24V DC to 12V DC converter)
Computer aided power optimization (New CAPO) system
3-power mode, 2-work mode, user mode
Auto deceleration & one-touch deceleration system
Auto warm-up system
Auto overheat prevention system
Automatic climate control
Air conditioner & heater
Defroster
Self-diagnostics system
Starting Aid (air grid heater) for cold weather
Centralized monitoring
LCD display
Engine speed or Trip meter/Accel.
Clock
Gauges
Fuel level gauge
Engine coolant temperature gauge
Hyd. oil temperature gauge
Warnings
Check engine
Overload
Communication error
Low battery
Air cleaner clogging
Indicators
Max power
Low speed/High speed
Fuel warmer
Auto idle
Door and cab locks, one key
Two outside rearview mirrors
Fully adjustable suspension seat with seat belt
Pilot-operated slidable joystick
Four front working lights (2 boom mounted, 2 front frame mounted)
Electric horn
Batteries (2 x 12V x 80 AH)
Battery master switch
Removable clean-out screen for oil cooler
Automatic swing brake
Removable reservoir tank
Fuel pre-filter
Boom holding system
Arm holding system
Track shoes (600mm, 24")
Track rail guard
Accumulator for lowering work equipment
Electric transducer
Lower frame under cover (Normal)

OPTIONAL EQUIPMENT

Fuel filler pump (35 L/min)
Beacon lamp
Single-acting piping kit (breaker, etc.)
Double-acting piping kit (clamshell, etc.)
Quick coupler
Travel alarm
Booms
4.1m, 13' 5"
4.6m, 15' 1"
Arms
1.9m, 6' 3"
2.1m, 6' 11"
2.5m, 8' 2"
3.0m, 9' 10"
Climate control
Air conditioner only
Heater only
Cabin FOPS / FOG (ISO / DIS 10262 Level II)
FOPS (Falling Object Protective Structure)
FOG (Falling Object Guard)
Cabin guard-Front
Wire net
Fine net
Cabin lights
Cabin front window rain guard
Sun visor
Track shoes
Triple grousers shoe (500mm, 20"), R140LCD-9S
Triple grousers shoe (700mm, 28")
Triple grousers shoe (800mm, 32"), R140LCM-9S
Double grousers shoe (710mm, 28"), R140LCM-9S
Single grousers shoe (960mm, 38"), R140LCM-9S
Full track rail guard
R140LCD-9S Blade : 550mm(1' 8") x 2,500mm(8' 2")
550mm(1' 8") x 2,600mm(8' 6")
Pre-heating system, coolant
Lower frame under cover (Additional)
Tool kit
Operator suit
Rearview camera
Seat
Mechanical suspension seat with heater
Hi-mate (Remote Management System)
Fuel warmer
Air compressor
Safety lock valve for Boom cylinder
Safety lock valve for Arm cylinder

- * Standard and optional equipment may vary. Contact your Hyundai dealer for more information. The machine may vary according to International standards.
- * The photos may include attachments and optional equipment that are not available in your area.
- * Materials and specifications are subject to change without advance notice.
- * All imperial measurements rounded off to the nearest pound or inch.

PLEASE CONTACT

 **HYUNDAI CONSTRUCTION EQUIPMENT**

MOVING YOU **FURTHER**

Robex
140LC-9S

With Tier 2 Engine installed



*Photo may include optional equipment.

Pride at Work

Hyundai Heavy Industries strives to build state-of-the-art earthmoving equipment to give every operator maximum performance, more precision, versatile machine preferences, and proven quality. Take pride in your work with Hyundai!

Robex 140LC-9S

Machine Walk-Around

Engine Technology

Proven / reliable, fuel efficient Cummins Tier II B3.9-C engine
Low noise / Auto engine warm up feature / Anti-restart feature

Hydraulic System Improvements

New patented hydraulic control for improved controllability / Improved control valve design for added efficiency and smoother operation / New auto boom and swing priority system for optimum speed / New auto power boost feature for additional power when needed / Improved arm-in and boom-down flow regeneration system for added speed and efficiency

Pump Compartment

Industry-leading, powerful, reliable Kawasaki designed, variable volume in-line axial piston pumps
New compact solenoid block equipped with 4 solenoid valves, 1 EPPR valves, 1 check valve accumulator and pilot filter - controls 2 speed travel, power boost, boom priority, safety lock

Enhanced Operator Cab

Improved visibility

New steel tube construction for added operator safety, protection and durability
New window open/close mechanism designed with cable and spring lift assist and single latch release

Improved Cab Construction

Ergonomic joysticks with auxiliary control buttons for attachment use. Now with new sleek styling
Adjustable arm rests - turn dial to raise or lower for optimum comfort

Improved Suspension Seat / Console Assembly

Ergonomic joysticks with auxiliary control buttons for attachment use. Now with new sleek styling
Adjustable arm rests - turn dial to raise or lower for optimum comfort

Advanced 7" Color Cluster

New Color LCD Display with easy to read digital gauges for hydraulic oil temperature, water temperature, and fuel / Simplified design makes adjustment and diagnostics easier. Also, new enhanced features such as rear-view camera are integrated into monitor.

3 power modes : (P) Power, (S) Standard, (E) Economy, 2 work modes : Dig & Attachment, (U) User mode for operator preference

Enhanced self-diagnostic features with GPS / satellite technology

One pump flow or two pump flow for optional attachment is now selectable through the cluster.

/ New anti-theft system with password capability

Boom speed and arm regeneration are selectable through the monitor.

Auto power boost is now available - selectable (on/off) through the monitor.

Powerful air conditioning and heat with auto climate control, 20% more heat and air output than 7 series!

RMS (Remote Management System) works through GPS/satellite technology to ultimately provide better customer service and support.

Undercarriage

Sealed track chain (urethane seals) / Standard track rail guard / Comfortable bolt-on steps
Large upper roller cut-outs for debris clean-out / Tapered side frames for debris clean-out / Grease type track tensioner

*Photo may include optional equipment.

Preference

Operating a 9S Series is unique to every operator. Operators can fully customize their work environment and operating preferences to fit their individual needs.



*Photo may include optional equipment.

Operator Comfort

In 9S Series cabin you can easily adjust the seat, console and armrest settings to best suit your personal operating preferences. Seat and console position can be set together and independent from each other. Other preference settings that add to overall operator comfort include the fully automatic high capacity airconditioning system and the radio / USB player.



Reduced Stress

Work is stressful enough. Your work environment should be stress free. Hyundai's 9S Series provides improved cab amenities, additional space and a comfortable seat to minimize stress to the operator. A powerful climate control system provides the operator with optimum air temperature. An advanced audio system with USB player, AM/FM stereo is perfect for listening to music favorites.



Operator - Friendly Cluster

The advanced new cluster with 7 inch wide color LCD screen and toggle switch allows the operator to select his personal machine preferences. Power and work mode selection, self diagnostics, optional rear-view camera, maintenance check lists, start-up machine security were integrated into the cluster to make the machine more versatile and the operator more productive.



Wide Cabin with Excellent Visibility

The newly designed cabin was conceived for more space, a wider field of view and operator comfort. Special attention was given to a clear, open and convenient interior with plenty of visibility on the machine surroundings and the job at hand. This well balanced combination of precision aspects put the operator in the perfect position to work safely and securely.



Precision

Innovative hydraulic system technologies make the 9S Series excavator fast, smooth and easy to control.



*Photo may include optional equipment.

Computer Aided Power

The engine horsepower and hydraulic horsepower together in unison through the advanced CAPO(Computer Aided Power Optimization) system, flow for the job at hand. Operator can set their own preferences for boom or swing priority, power mode selection and optional work tools at the touch of a button.

The CAPO system also provides complete self diagnostic features and digital gauges for important information like hydraulic oil temperature, water temperatures and fuel level. This system interfaces with multiple sensors placed throughout the hydraulic system as well as hydraulic flow.

Power Mode

P (Power Max) mode maximizes machine speed and power for mass production. S (Standard) mode provides a reduced, fixed rpm for optimum performance and improved fuel economy. For maximum fuel savings and improved control, E (Economy) mode provides precise flow based on load demand. Three unique power modes provide the operator with custom power, speed and fuel economy.

Work Mode

The work mode allows the operator to select single flow attachments like a hydraulic breaker or bi-directional flow attachments like a crusher. Flow settings unique to each attachment can be programmed from within the cluster.

User Mode

Some jobs require more precise machine settings. Using the versatile U (User) mode, the operator can customize engine speed, pump output, idle speed and other machine settings for the job at hand.

Improved Hydraulic System



To achieve optimum precision, Hyundai redesigned the hydraulic system to provide the operator with super fine touch and improved controllability. Improved pump flow control reduces flow when controls are not being used to minimize fuel consumption.

Improved spool valves in the control valve are engineered to provide more precise flow to each function with less effort.

Improved hydraulic valves, precision-designed variable volume piston pumps, fine-touch pilot controls, and enhanced travel functions make any operator running a 9S

Series look like a smooth operator. Newly improved features include arm-in and boom-down flow regeneration, improved control valve technology and innovative auto boom and swing priority for optimal performance in any application.



Auto Boom-swing Priority

This smart function automatically and continuously looks the ideal hydraulic flow balance for the boom and swing motions of the machine. The advanced CAPO system monitors the hydraulic system and adjusts its settings to maximize performance and productivity.

Performance

9S Series is designed for maximum performance to keep the operator working productively.



*Photo may include optional equipment.



Track Rail Guard & Adjusters

standard grease cylinder track adjusters and shock absorbing springs.

Durable track rail guards keep track links in place. Track adjustment is made easy with

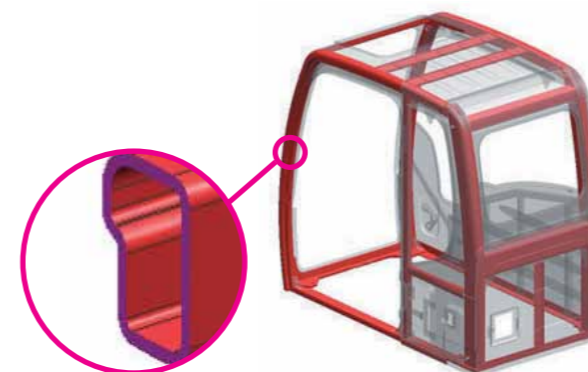

Structural Strength

The 9S Series cabin structure has been fitted with stronger but slimmer tubing for more safety and improved visibility. Low-stress, high strength steel is integrally welded to form a stronger, more durable upper and lower frame. Structural integrity was tested by way of FEM (Finite Elements Method) analysis and long-term durability tests.

CUMMINS B3.9C ENGINE

The 4 cylinders, turbo-charged, 4 cycle, charger air cooled engine is built for power, reliability, economy and low emissions.

A More Reliable Way To Reach Your Dream.

The Cummins B3.9-C engine has been designed with 40% fewer parts than the competition. That means there's less that can go wrong when you need it most. It also means fewer parts to inventory. Repairs are simplified because no special tools are needed for maintenance. The weight of the machine is reduced without sacrificing strength.

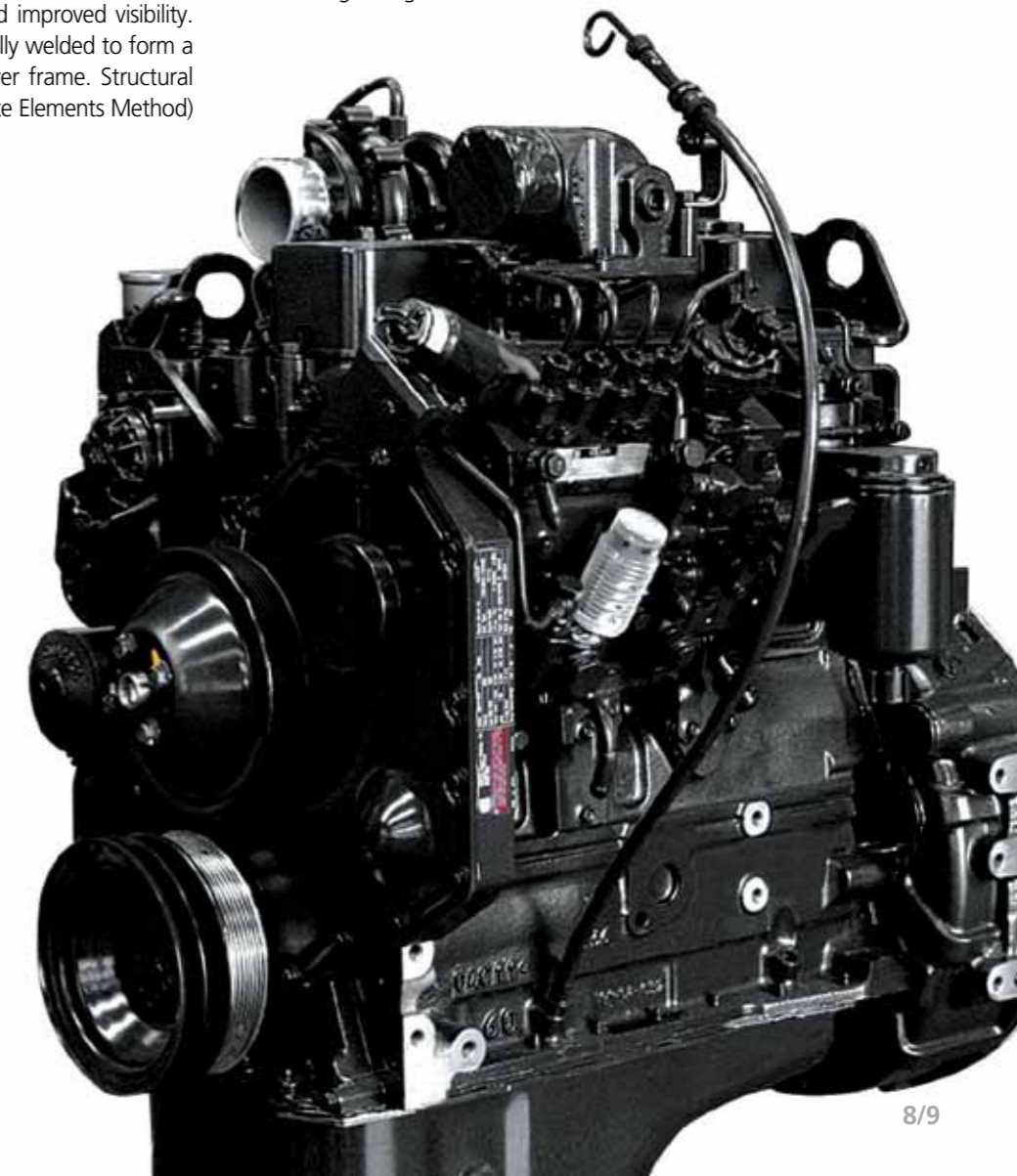

Profitability

9S Series is designed to maximize profitability through improved efficiencies, enhanced service features and longer life components.



*Photo may include optional equipment.

Fuel Efficiency

9S Series excavators are engineered to be extremely fuel efficient. New innovations like two-stage auto decel system and the new economy mode help to conserve fuel and reduce the impact on the environment.



Hi-MATE (Remote Management System)

Hi-MATE, Hyundai's proprietary remote management system, provides operators and dealer service personnel access to vital service and diagnostic information on the machine from any computer with internet access. Users can pinpoint machine location using digital mapping and set machine work boundaries, reducing the need for multiple service calls. Hi-MATE saves time and money for the owner and dealer by promoting preventative maintenance and reducing machine downtime.



Easy Access

Ground-line access to filters, lube fittings, fuses, machine computer components and wide open compartments makes service more convenient on the 9S Series.



Extended Life Components

9S series excavators were designed with bushings designed for extended lube intervals (250hrs) & polymer shims (wear resistant, noise reducing), extended-life hydraulic filters (1,000hrs), long-life hydraulic oil (5,000hrs), more efficient cooling systems and integrated preheating systems which extend service intervals, minimize operating costs and reduce machine downtime.

Specifications

ENGINE

MODEL		CUMMINS B3.9-C	
Type		Water cooled, 4 cycle Diesel, 4-cylinders in line, direct injection, turbocharged, charger air cooled, low emission	
Rated flywheel horsepower	SAE	J1995 (gross)	113 HP (84kW) at 2,100 rpm
		J1349 (net)	105 HP (78 kW) at 2,100 rpm
	DIN	6271/1 (gross)	115 PS (84 kW) at 2,100 rpm
		6271/1 (net)	106 PS (78 kW) at 2,100 rpm
Max. torque		45.6 kgf·m (330lbf·ft) / 1,500 rpm	
Bore X stroke		102 mm X 120 mm (4.02" X 4.72")	
Piston displacement		3,900cc (238 in³)	
Batteries		2 X 12V X 80AH	
Starting motor		24V, 4.5 kW	
Alternator		24V, 70 Amp	

HYDRAULIC SYSTEM

MAIN PUMP	
Type	Variable displacement tandem-axis piston pumps
Rated flow	2 X 126.8L /min (33.5 US gpm / 27.9 UK gpm)
Sub-pump for pilot circuit	Gear pump

Cross-sensing and fuel saving pump system.

HYDRAULIC MOTORS	
Travel	Two speed axial pistons motor with brake valve and parking brake
Swing	Axial piston motor with automatic brake

RELIEF VALVE SETTING	
Implement circuits	350 kgf/cm² (4,978 psi)
Travel	350 kgf/cm² (4,978 psi)
Power boost (boom, arm, bucket)	380 kgf/cm² (5,404 psi)
Swing circuit	285 kgf/cm² (4,054 psi)
Pilot circuit	40 kgf/cm² (568 psi)
Service valve	Installed

HYDRAULIC CYLINDERS	
No. of cylinder bore X stroke	Boom: 2-105 X 1,075 mm(4.1" X 42.3")
	Arm: 1-115 X 1,138 mm (4.5" X 44.8")
	Bucket: 1-100 X 840 mm (3.9" X 32.6")
	Blade: 2-100 X 250 mm (3.9" X 9.8")

DRIVES & BRAKES

Drive method	Fully hydrostatic type
Drive motor	Axial piston motor, in-shoe design
Reduction system	Planetary reduction gear
Max. drawbar pull	13,300 kgf (29,320 lbf)
Max. travel speed(high) / (low)	5.6 km/hr (3.5 mph) / 3.6 km/hr (2.2 mph)
Gradeability	35° (70 %)
Parking brake	Multi wet disc

CONTROL

Pilot pressure operated joysticks and pedals with detachable lever provide almost effortless and fatigueless operation.

Pilot control	Two joysticks with one safety lever (LH): Swing and arm, (RH): Boom and bucket(ISO)
Traveling and steering	Two levers with pedals
Engine throttle	Electric, Dial type

SWING SYSTEM

Swing motor	Fixed displacement axial pistons motor
Swing reduction	Planetary gear reduction
Swing bearing lubrication	Grease-bathed
Swing brake	Multi wet disc
Swing speed	13 rpm

COOLANT & LUBRICANT CAPACITY

Refilling	liter	US gal	UK gal
Fuel tank	270.0	71.3	59.4
Engine coolant	15.5	4.1	3.4
Engine oil	15.3	4.0	3.4
Swing device-gear oil	2.5	0.66	0.55
Final drive(each)-gear oil	2.2	0.60	0.50
Hydraulic system(including tank)	210.0	55.5	46.2
Hydraulic tank	124.0	32.8	27.3

UNDERCARRIAGE

The X-leg type center frame is integrally welded with reinforced box-section track frames. The undercarriage includes lubricated rollers, idlers, track adjusters with shock absorbing springs and sprockets, and a track chain with triple grouser shoes.

	R140LC-9S / R140LCD-9S	R140LCM-9S
Center frame	X - leg type	
Track frame	Pentagonal box type	
No. of shoes on each side	46 EA	47 EA
No. of carrier roller on each side	2 EA	2 EA
No. of track roller on each side	7 EA	7 EA
No. of rail guard on each side	1 EA	2 EA

OPERATING WEIGHT (APPROXIMATE)

Operating weight, including 4,600mm (15' 1") boom, 2,500mm (8' 2") arm, SAE heaped 0.58m³ (0.76 yd³) bucket, lubricant, coolant, full fuel tank, full hydraulic tank, and all standard equipments.

MAJOR COMPONENT WEIGHT	
Upperstructure	3,820 kg (8,422 lb)
Boom (with arm cylinder)	1,030 kg (2,270 lb)

OPERATING WEIGHT			
Shoes	Operating weight		Ground pressure
Type	Width mm(in)	kg (lb)	kgf/cm² (psi)
Triple grouser	500 mm (20")	R140LC-9S	13,790 (30,400) 0.43 (6.11)
		R140LCD-9S	14,590 (32,160) 0.45 (6.40)
	600 mm (24")	R140LC-9S	13,980 (30,820) 0.36 (5.12)
		R140LCD-9S	14,800 (32,630) 0.38 (5.40)
	700 mm (28")	R140LC-9S	14,210 (31,330) 0.32 (4.55)
		R140LCM-9S	16,880 (37,210) 0.32 (4.55)
Double grouser	710 mm (28")	R140LCM-9S	16,880 (37,210) 0.36 (5.12)
Single grouser	960 mm (38")	R140LCM-9S	17,080 (37,655) 0.27 (3.84)

AIR CONDITIONING SYSTEM

The air condition system for the machine contains the fluorinated greenhouse gas with global warming potential of R134a. (Global Warming Potential : 1430)

The system hold 0.75kg refrigerant consisting of a CO2 equivalent 1.07kg metric tonne. For more information, Please refer to the manual.

BUCKETS

All buckets are welded with high-strength steel.

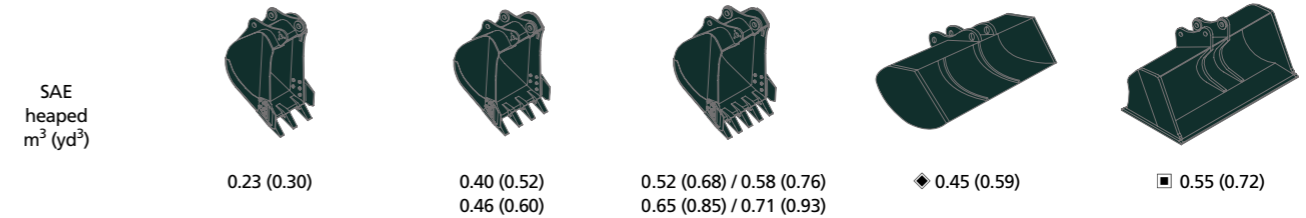

Capacity m³ (yd³)		Width mm (in)		Weight kg (lb)	Recommendation mm (ft-in)					
SAE heaped	CECE heaped	Without side cutters	With side cutters		4,600 (15' 1") Boom				4,100 (13' 5") Boom	
					1,900 (6' 3") Arm	2,100 (6' 11") Arm	2,500 (8' 2") Arm	3,000 (9' 10") Arm	1,900 (6' 3") Arm	2,100 (6' 11") Arm
0.23 (0.30)	0.20(0.26)	520(20.5)	620(24.4)	335(740)	●	●	●	■	●	●
0.40 (0.52)	0.35(0.46)	760(29.9)	860(33.9)	410(900)	●	●	●	■	●	●
0.46 (0.60)	0.40(0.52)	850(33.5)	950(37.4)	435(960)	●	●	●	▲	●	●
0.52 (0.68)	0.45(0.59)	935(36.8)	1,035(40.8)	460(1,010)	●	●	●	-	●	●
0.58 (0.76)	0.50(0.65)	1,030(40.6)	1,130(44.5)	480(1,060)	●	●	■	-	●	●
0.65 (0.85)	0.55(0.72)	1,110(43.7)	1,210(47.6)	500(1,100)	■	■	▲	-	●	■
0.71 (0.93)	0.60(0.78)	1,205(47.4)	-	540(1,190)	▲	▲	-	-	■	▲
◆ 0.45 (0.59)	0.40(0.52)	1,520(59.8)	-	410(900)	●	●	■	-	●	●
■ 0.55 (0.72)	0.45(0.59)	1,800(70.9)	-	585(1,290)	■	■	▲	-	●	●

- ◆ Ditching bucket
- Heavy duty bucket

- : Applicable for materials with density of 2,000 kg /m³ (3,370 lb/ yd³) or less
- : Applicable for materials with density of 1,600 kg /m³ (2,700 lb/ yd³) or less
- ▲: Applicable for materials with density of 1,100 kg /m³ (1,850 lb/ yd³) or less

ATTACHMENT

Booms and arms are welded, a low-stress, full-box section design. 4.1m, 4.6m mono booms and 1.9m, 2.1m, 2.5m, 3.0m arms are available.

DIGGING FORCE

Boom	Length	mm (ft-in)	4,600 (15' 1")				Remarks
	Weight	kg (lb)	1,030 (2,270)				
Arm	Length	mm (ft-in)	1,900 (6' 3")	2,100 (6' 11")	2,500 (8' 2")	3,000 (9' 10")	Power Boost
	Weight	kg (lb)	560 (1,230)	580 (1,280)	610 (1,340)	670 (1,480)	
Bucket digging force	SAE	kN	87.3[94.8]	87.3[94.8]	87.3[94.8]	87.3[94.8]	[]: Power Boost
		kgf	8,900[9,660]	8,900[9,660]	8,900[9,660]	8,900[9,660]	
		lbf	19,620[21,300]	19,620[21,300]	19,620[21,300]	19,620[21,300]	
	ISO	kN	102[110.8]	102[110.8]	102[110.8]	102[110.8]	
		kgf	10,400[11,290]	10,400[11,290]	10,400[11,290]	10,400[11,290]	
		lbf	22,930[24,890]	22,930[24,890]	22,930[24,890]	22,930[24,890]	
Arm crowd force	SAE	kN	76.5[83.1]	73.6[79.9]	62.8[68.2]	55.9[60.7]	[]: Power Boost
		kgf	7,800[8,470]	7,500[8,140]	6,400[6,950]	5,700[6,190]	
		lbf	17,200[18,670]	16,530[17,950]	14,110[15,320]	12,570[13,640]	
	ISO	kN	80.4[87.3]	77.5[84.1]	65.7[71.4]	57.9[62.8]	
		kgf	8,200[8,900]	7,900[8,580]	6,700[7,270]	5,900[6,410]	
		lbf	18,080[19,630]	17,420[18,910]	14,770[16,040]	13,010[14,120]	

Note: Boom weight includes arm cylinder, piping, and pin
Arm weight includes bucket cylinder, linkage, and pin

Dimensions & Working Range

R140LC-9S DIMENSIONS

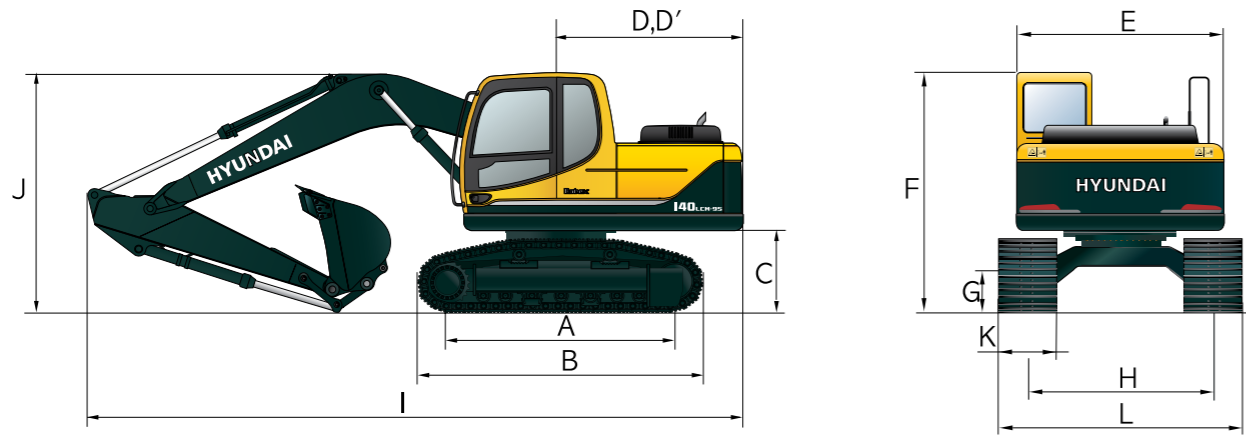

Unit : mm (ft-in)

A Tumbler distance	3,000 (9' 10")	Boom length	4,600 (15' 1")				4,100 (13' 5")	
B Overall length of crawler	3,750 (12' 4")	Arm length	1,900 (6' 3")	2,100 (6' 11")	2,500 (8' 2")	3,000 (9' 10")	1,900 (6' 3")	2,100 (6' 11")
C Ground clearance of counterweight	940 (3' 1")	I Overall length	7,820 (25' 7")	7,850 (25' 8")	7,820 (25' 7")	7,790 (25' 6")	7,320 (24' 0")	7,350 (24' 1")
D Tail swing radius	2,330 (7' 7")	J Overall height of boom	2,650 (8' 7")	2,760 (9' 0")	2,780 (9' 1")	3,110 (10' 2")	2,600 (8' 5")	2,790 (9' 2")
D' Rear-end length	2,330 (7' 7")	K Track shoe width	500 (20")		600 (24")		700 (28")	
E Overall width of upperstructure	2,500 (8' 2")	L Overall width	2,500 (8' 2")		2,600 (8' 6")		2,700 (8' 10")	
F Overall height of cab	2,860 (9' 4")							
G Min. ground clearance	440 (1' 5")							
H Track gauge	2,000 (6' 7")							

R140LC-9S WORKING RANGE

Unit : mm (ft-in)

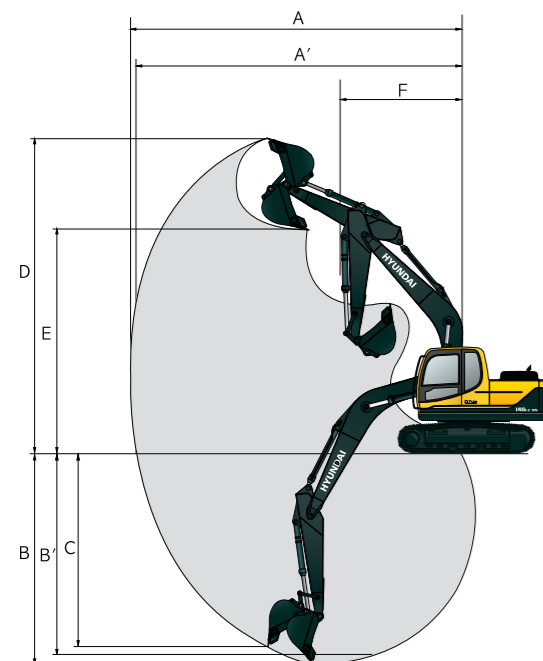

Boom length	4,600 (15' 1")				4,100 (13' 5")	
Arm length	1,900 (6' 3")	2,100 (6' 11")	2,500 (8' 2")	3,000 (9' 10")	1,900 (6' 3")	2,100 (6' 11")
A Max. digging reach	7,750 (25' 5")	7,920 (25' 11")	8,330 (27' 4")	8,790 (28' 10")	7,260 (23' 10")	7,420 (24' 4")
A' Max. digging reach on ground	7,600 (24' 11")	7,770 (25' 6")	8,180 (26' 10")	8,650 (28' 4")	7,090 (23' 3")	7,260 (23' 10")
B Max. digging depth	4,950 (16' 2")	5,150 (16' 10")	5,550 (18' 3")	6,050 (19' 10")	4,540 (14' 11")	4,740 (15' 7")
B' Max. digging depth (8' level)	4,680 (15' 4")	4,900 (16' 1")	5,340 (17' 6")	5,870 (19' 3")	4,280 (14' 1")	4,490 (14' 9")
C Max. vertical wall digging depth	4,650 (15' 3")	4,900 (16' 1")	5,330 (17' 6")	5,850 (19' 2")	4,240 (13' 11")	4,350 (14' 3")
D Max. digging height	8,100 (26' 7")	8,180 (26' 10")	8,500 (27' 11")	8,780 (28' 10")	7,700 (25' 3")	7,770 (25' 6")
E Max. dumping height	5,670 (18' 7")	5,750 (18' 10")	6,060 (19' 11")	6,330 (20' 9")	5,260 (17' 3")	5,340 (17' 6")
F Min. swing radius	2,630 (8' 8")	2,670 (8' 9")	2,650 (8' 8")	2,680 (8' 10")	2,350 (7' 9")	2,460 (8' 1")

Dimensions & Working Range

R140LCD-9S DIMENSIONS

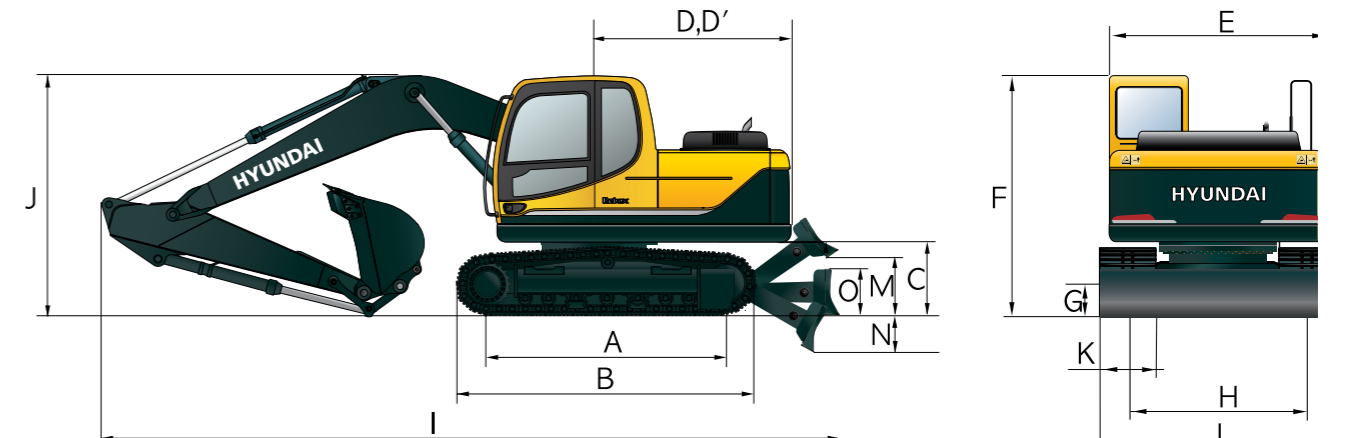

Unit : mm (ft-in)

A Tumbler distance	3,000 (9' 10")	Boom length	4,600 (15' 1")				4,100 (13' 5")	
B Overall length of crawler	3,750 (12' 4")	Arm length	1,900 (6' 3")	2,100 (6' 11")	2,500 (8' 2")	3,000 (9' 10")	1,900 (6' 3")	2,100 (6' 11")
C Ground clearance of counterweight	940 (3' 1")	I Overall length	8,130 (26' 7")	8,160 (26' 7")	8,130 (26' 7")	8,100 (26' 6")	7,630 (25' 0")	7,660 (25' 1")
D Tail swing radius	2,330 (7' 7")	J Overall height of boom	2,650 (8' 7")	2,760 (9' 0")	2,780 (9' 1")	3,110 (10' 2")	2,600 (8' 5")	2,790 (9' 2")
D' Rear-end length	2,330 (7' 7")	K Track shoe width	500 (20")		600 (24")		700 (28")	
E Overall width of upperstructure	2,500 (8' 2")	L Overall width	2,500 (8' 2")		2,600 (8' 6")		2,700 (8' 10")	
F Overall height of cab	2,860 (9' 4")							
G Min. ground clearance	440 (1' 5")							
H Track gauge	2,000 (6' 7")							
M Ground clearance of blade up	560 (1' 8")							
N Depth of blade down	500 (1' 6")							
O Height of blade	550 (1' 8")							
Width of blade	2,500 (8' 2") 2,600 (8' 6")							

R140LCD-9S WORKING RANGE

Unit : mm (ft . in)

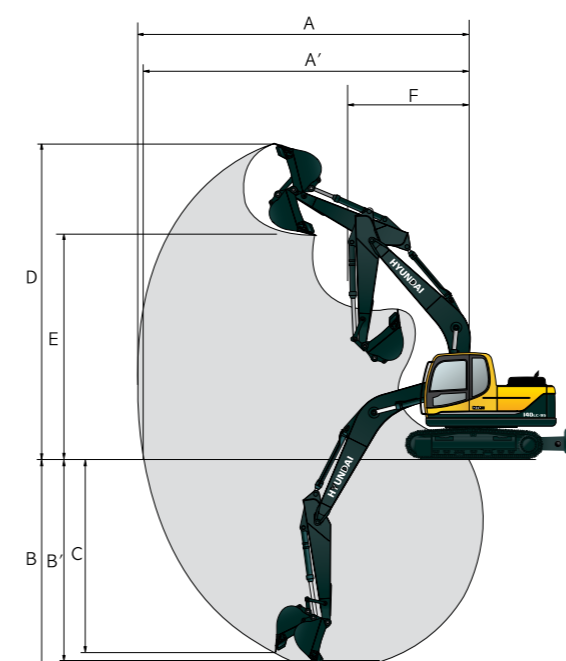

Boom length	4,600 (15' 1")				4,100 (13' 5")	
Arm length	1,900 (6' 3")	2,100 (6' 11")	2,500 (8' 2")	3,000 (9' 10")	1,900 (6' 3")	2,100 (6' 11")
A Max. digging reach	7,750 (25' 5")	7,920 (25' 11")	8,330 (27' 4")	8,790 (28' 10")	7,260 (23' 10")	7,420 (24' 4")
A' Max. digging reach on ground	7,600 (24' 11")	7,770 (25' 6")	8,180 (26' 10")	8,650 (28' 4")	7,090 (23' 3")	7,260 (23' 10")
B Max. digging depth	4,950 (16' 2")	5,150 (16' 10")	5,550 (18' 3")	6,050 (19' 10")	4,540 (14' 11")	4,740 (15' 7")
B' Max. digging depth (8' level)	4,680 (15' 4")	4,900 (16' 1")	5,340 (17' 6")	5,870 (19' 3")	4,280 (14' 1")	4,490 (14' 9")
C Max. vertical wall digging depth	4,650 (15' 3")	4,900 (16' 1")	5,330 (17' 6")	5,850 (19' 2")	4,240 (13' 11")	4,350 (14' 3")
D Max. digging height	8,100 (26' 7")	8,180 (26' 10")	8,500 (27' 11")	8,780 (28' 10")	7,700 (25' 3")	7,770 (25' 6")
E Max. dumping height	5,670 (18' 7")	5,750 (18' 10")	6,060 (19' 11")	6,330 (20' 9")	5,260 (17' 3")	5,340 (17' 6")
F Min. swing radius	2,630 (8' 8")	2,670 (8' 9")	2,650 (8' 8")	2,680 (8' 10")	2,350 (7' 9")	2,460 (8' 1")

Dimensions & Working Range

R140LCM-9S DIMENSIONS

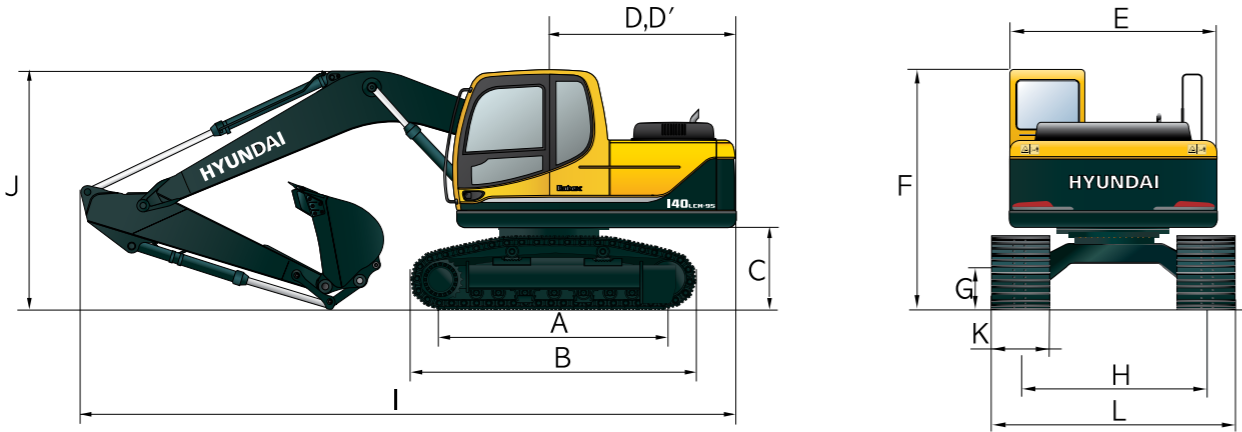

Unit: mm (ft-in)

A Tumbler distance	3,030 (9' 11")	Boom length	4,600 (15' 1")			
B Overall length of crawler	3,860 (12' 4")	Arm length	1,900 (6' 3")	2,100 (6' 11")	2,500 (8' 2")	3,000 (9' 10")
C Ground clearance of counterweight	1,200 (3' 9")	I Overall length	7,770 (25' 5")	7,830 (25' 7")	7,790 (25' 6")	7,860 (25' 8")
D Tail swing radius	2,330 (7' 7")	J Overall height	2,750 (9' 0")	2,860 (9' 4")	2,830 (9' 3")	3,120 (10' 2")
D' Rear-end length	2,330 (7' 7")	K Track shoe width	Type	Double grouser	Triple grouser	Single grouser
E Overall width of upperstructure	2,500 (8' 2")	L Overall width	Width	710 (28")	800 (32")	960 (38")
F Overall height of cab	3,120 (10' 2")			2,750 (9' 0")	2,840 (9' 4")	3,000 (9' 10")
G Min. ground clearance	600 (2' 0")					
H Track gauge	2,040 (6' 8")					

R140LCM-9S WORKING RANGE

Unit: mm (ft-in)

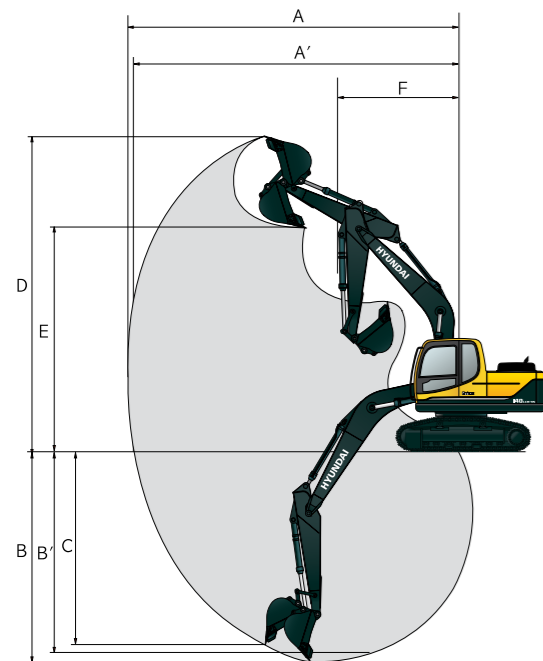

Boom length	4,600 (15' 1")			
Arm length	1,900 (6' 3")	2,100 (6' 11")	2,500 (8' 2")	3,000 (9' 10")
A Max. digging reach	7,750 (25' 5")	7,920 (25' 11")	8,330 (27' 4")	8,790 (28' 10")
A' Max. digging reach on ground	7,540 (24' 9")	7,710 (25' 4")	8,110 (26' 7")	8,580 (28' 2")
B Max. digging depth	4,690 (15' 5")	4,890 (16' 1")	5,290 (17' 4")	5,790 (19' 0")
B' Max. digging depth (8' level)	4,420 (14' 6")	4,640 (15' 3")	5,080 (16' 8")	5,610 (18' 5")
C Max. vertical wall digging depth	4,390 (14' 5")	4,640 (15' 3")	5,070 (16' 8")	5,590 (18' 4")
D Max. digging height	8,360 (27' 5")	8,440 (27' 8")	8,760 (28' 9")	9,040 (29' 7")
E Max. dumping height	5,930 (19' 5")	6,010 (19' 8")	6,320 (20' 9")	6,590 (21' 7")
F Min. swing radius	2,630 (8' 8")	2,670 (8' 9")	2,650 (8' 8")	2,680 (8' 10")

Lifting Capacity

R140LC-9S

Rating over-front Rating over-side or 360 degree

Boom : 4.6 m (15' 1") / Arm : 1.9 m (6' 3") / Bucket : 0.58 m³ (0.76 yd³) SAE heaped / Shoe : 600mm(24") triple grouser

Load point height m (ft)		Load radius								At max. reach		
		1.5 m (5 ft)		3.0 m (10 ft)		4.5 m (15 ft)		6.0 m (20 ft)		Capacity	Reach	
6.0 m (20 ft)	kg					*3340	*3340			*3170	2350	5.95
	lb					*7360	*7360			*6990	5180	(19.5)
4.5 m (15 ft)	kg					*3550	*3550			2820	1760	6.90
	lb					*7830	*7830			6220	3880	(22.6)
3.0 m (10 ft)	kg			*6270	*6270	*4440	3510	3480	2170	2480	1520	7.37
	lb			*13820	*13820	*9790	7740	7670	4780	5470	3350	(24.2)
1.5 m (5 ft)	kg			*8490	6040	5400	3270	3380	2080	2390	1450	7.45
	lb			*18720	13320	11900	7210	7450	4590	5270	3200	(24.4)
Ground Line	kg			*8230	5790	5200	3100	3300	2000	2510	1520	7.17
	lb			*18140	12760	11460	6830	7280	4410	5530	3350	(23.5)
-1.5 m (-5 ft)	kg	*6670	*6670	*9690	5800	5140	3050			2960	1810	6.48
	lb	*14700	*14700	*21360	12790	11330	6720			6530	3990	(21.3)
-3.0 m (-10 ft)	kg	*10970	*10970	*8330	5930	5220	3110			*3690	2670	5.15
	lb	*24180	*24180	*18360	13070	11510	6860			*8140	5890	(16.9)

Boom : 4.6 m (15' 1") / Arm : 2.1 m (6' 11") / Bucket : 0.58 m³ (0.76 yd³) SAE heaped / Shoe : 600mm(24") triple grouser

Load point height m (ft)		Load radius								At max. reach		
		1.5 m (5 ft)		3.0 m (10 ft)		4.5 m (15 ft)		6.0 m (20 ft)		Capacity	Reach	
6.0 m (20 ft)	kg					*3090	*3090			*3030	2210	6.17
	lb					*6810	*6810			*6680	4870	(20.2)
4.5 m (15 ft)	kg					*3340	*3340	*2900	2240	2700	1680	7.09
	lb					*7360	*7360	*6390	4940	5950	3700	(23.3)
3.0 m (10 ft)	kg			*5810	*5810	*4230	3530	3490	2170	2380	1450	7.54
	lb			*12810	*12810	*9330	7780	7690	4780	5250	3200	(24.7)
1.5 m (5 ft)	kg			*8760	6090	*5340	3270	3370	2070	2290	1380	7.62
	lb			*19310	13430	*11770	7210	7430	4560	5050	3040	(25.0)
Ground Line	kg			*8470	5770	5180	3080	3280	1980	2400	1440	7.35
	lb			*18670	12720	11420	6790	7230	4370	5290	3170	(24.1)
-1.5 m (-5 ft)	kg	*6370	*6370	*9780	5740	5110	3010	3250	1950	2800	1700	6.68
	lb	*14040	*14040	*21560	12650	11270	6640	7170	4300	6170	3750	(21.9)
-3.0 m (-10 ft)	kg	*10300	*10300	*8590	5850	5160	3060			*3700	2430	5.41
	lb	*22710	*22710	*18940	12900	11380	6750			*8160	5360	(17.7)

Boom : 4.6 m (15' 1") / Arm : 2.5 m (8' 2") / Bucket : 0.58 m³ (0.76 yd³) SAE heaped / Shoe : 600mm(24") triple grouser

Load point height m (ft)		Load radius								At max. reach		
		1.5 m (5 ft)		3.0 m (10 ft)		4.5 m (15 ft)		6.0 m (20 ft)		Capacity	Reach	
6.0 m (20 ft)	kg									*2810	1920	6.69
	lb									*6190	4230	(21.9)
4.5 m (15 ft)	kg							*2770	2270	2440	1500	7.53
	lb							*6110	5000	5380	3310	(24.7)
3.0 m (10 ft)	kg			*4930	*4930	*3830	3570			*3380	2190	7.95
	lb			*10870	*10870	*8440	7870			*7450	4830	(26.1)
1.5 m (5 ft)	kg			*8030	6240	*5010	3300			3380	2070	2100
	lb			*17700	13760	*11050	7280			7450	4560	4630
Ground Line	kg			*8780	5800	5200	3090			3270	1970	2180
	lb			*19360	12790	11460	6810			7210	4340	4810
-1.5 m (-5 ft)	kg	*5740	*5740	*9910	5700	5080	2990			3220	1920	2500
	lb	*12650	*12650	*21850	12570	11200	6590			7100	4230	5510
-3.0 m (-10 ft)	kg	*8760	*8760	*9040	5770	5100	3000					3340
	lb	*19310	*19310	*19930	12720	11240	6610					7360
-3.0 m (-10 ft)	kg			*6590	6030							
	lb			*14530	13290							

- Lifting capacity is based on SAE J1097, ISO 10567.
- Lifting capacity of the Robex Series does not exceed 75% of the tipping load with the machine on firm, level ground or 87% of full hydraulic capacity.
- The load point is a hook located on the back of the bucket.
- (*) indicates the load limited by hydraulic capacity.

